

Outside Rail Hoist

OR Series



- Most popular cable roll-off hoist in the market
- Heavy duty 1/2" thick mainframe
- Inside controls standard reducing the chance of driver injury
- 48 degree dump angle on all models
- Durable rear hinge designed to withstand the stress of grueling day after day use
- 2 minute loading cycle time* keeping your drivers on the road
- Available in 60k and 75k pound models to fit any application.



The Galfab Advantage



Outboard Supported Side Rollers

Greasable roller shaft is removable with two bolts.



Container Support Rails

Rails aid in loading misaligned containers and give added support to the long sills increasing the life of your container.



Auto Fold Bumper (Hoist Up)

Bumper folds forward reducing the chance of bending and hang-ups in the landfill.



Auto Fold Bumper (Hoist Down)

Bumper extends downward to normal position in the hoist down position.

Standard Features

- 8 x 4 x 1/2" Tube Main Frame
- 3 x 2 x 1/4" Tube Sub Frame
- 2 1/2" Diameter Rear Hinge
- All Working Points Greasable
- 1" Spring Loaded Container Locks
- 2 1/2" Diameter Lift Cylinder Shafts
- 10" Diameter Cable Sheaves
- 52 Gallon Oil Reservoir
- Suction Screen and Return Filter
- Inside and Outside Controls
- Sealed Lighting System

Options

- Behind Cab and Oversize Oil Tanks
- Tool Boxes
- Auxiliary Stops
- Poly or Steel Fenders
- Tarping Systems
- Hooker Hold On Systems
- Ratchet Tie Down Straps
- Pintle Hook
- Front Mount Pump
- PTO
- Drop Shaft

DISTRIBUTED BY:

Outside Rail Hoist

OR Series

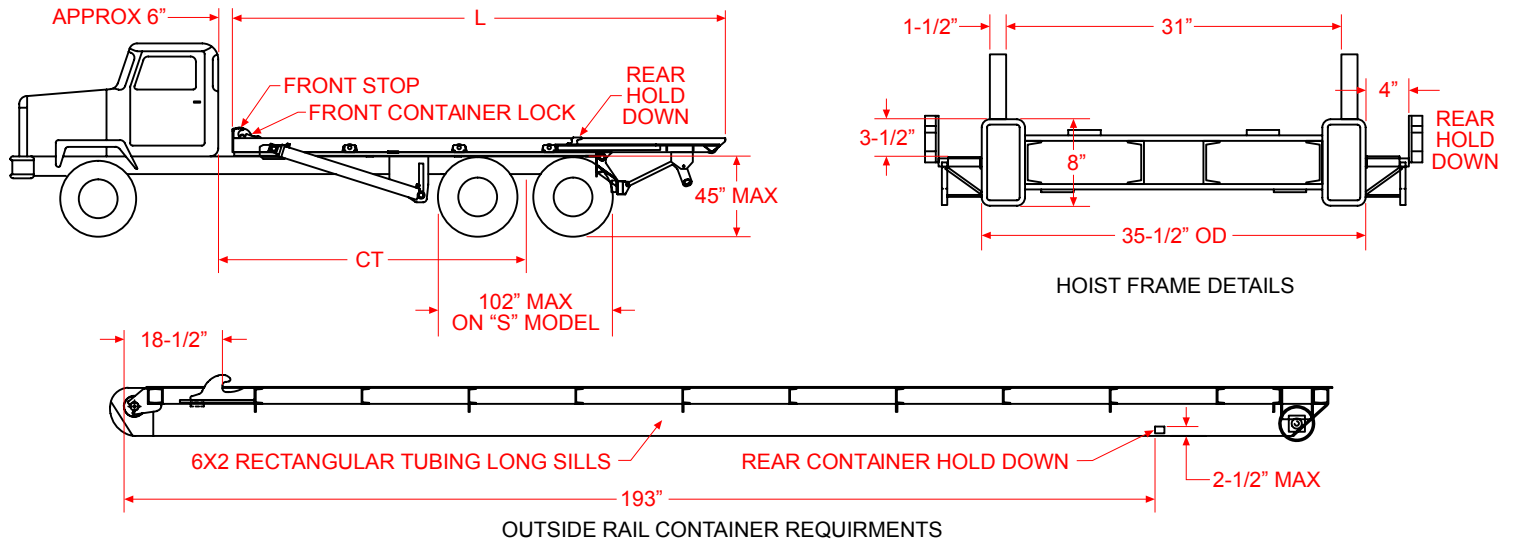

Model	Rated Cap.	CT	L	Dump Angle	Up (Sec.)*	Down (Sec.)*	On (Sec.)*	Off (Sec.)*	Lift Cylinder	Winch Cylinder	Container Length	Appx. Wgt.
OR 60174 S074.5	60,000#	174"	23' 3"	48 deg.	29	15	46	37	6" - 4 1/2" x 74 1/2" DA	7" - 3" x 81 1/2" DA	18' to 22'	7150#
OR 60174 T121	60,000#	174"	23' 3"	48 deg.	49	20	46	37	6" - 5" - 4" x 121" DAT	7" - 3" x 81 1/2" DA	18' to 22'	7225#
OR 60194 T121	60,000#	194"	24' 11"	48 deg.	49	20	50	40	6" - 5" - 4" x 121" DAT	7" - 3" x 91 1/2" DA	20' to 24'	8075#
OR 75174 T121	75,000#	174"	23' 3"	48 deg.	49	20	46	37	6" - 5" - 4" x 121" DAT	7" - 3" x 81 1/2" DA	18' to 22'	7350#
OR 75194 T121	75,000#	194"	24' 11"	48 deg.	49	20	50	40	6" - 5" - 4" x 121" DAT	7" - 3" x 91 1/2" DA	20' to 24'	8200#
OR 60194 T083	60,000#	194"	24' 11"	48 deg.	29	15	46	40	5" - 4" x 83" DAT	7" - 3" x 91 1/2" DA	20' to 24'	7200#
OR 60194 T114	60,000#	194"	24' 11"	48 deg.	49	20	50	40	6" - 5" x 114" DAT	7" - 3" x 91 1/2" DA	20' to 24'	8100#
OR 60194 T138	60,000#	229"	28' 5"	48 deg.	60	24	72	59	6" - 5" - 4" x 138" DAT	7" - 3" x 91 1/2" DA	24' to 28'	9000#

* Cycle Times are Factory developed and controlled by PTO output, oil viscosity, human and mechanical efficiency, and may vary accordingly.

All dimensions are subject to steel and manufacturing tolerances.

CAUTION: This Equipment Should be Operated by Properly Trained Personnel. Improper Use, Misuse or Lack of Maintenance Could Cause Injury to Persons or Property. Photos used in this brochure are illustrative only. We reserve the right to make changes at any time without notice. Information contained within this literature is believed to be the most accurate available at the time of printing.

Additional Features



Optional "The Hooker" Securement System



Sliding Ratchet Tie Down Straps



Auxiliary Fold Down Stops